

HC 350 A1

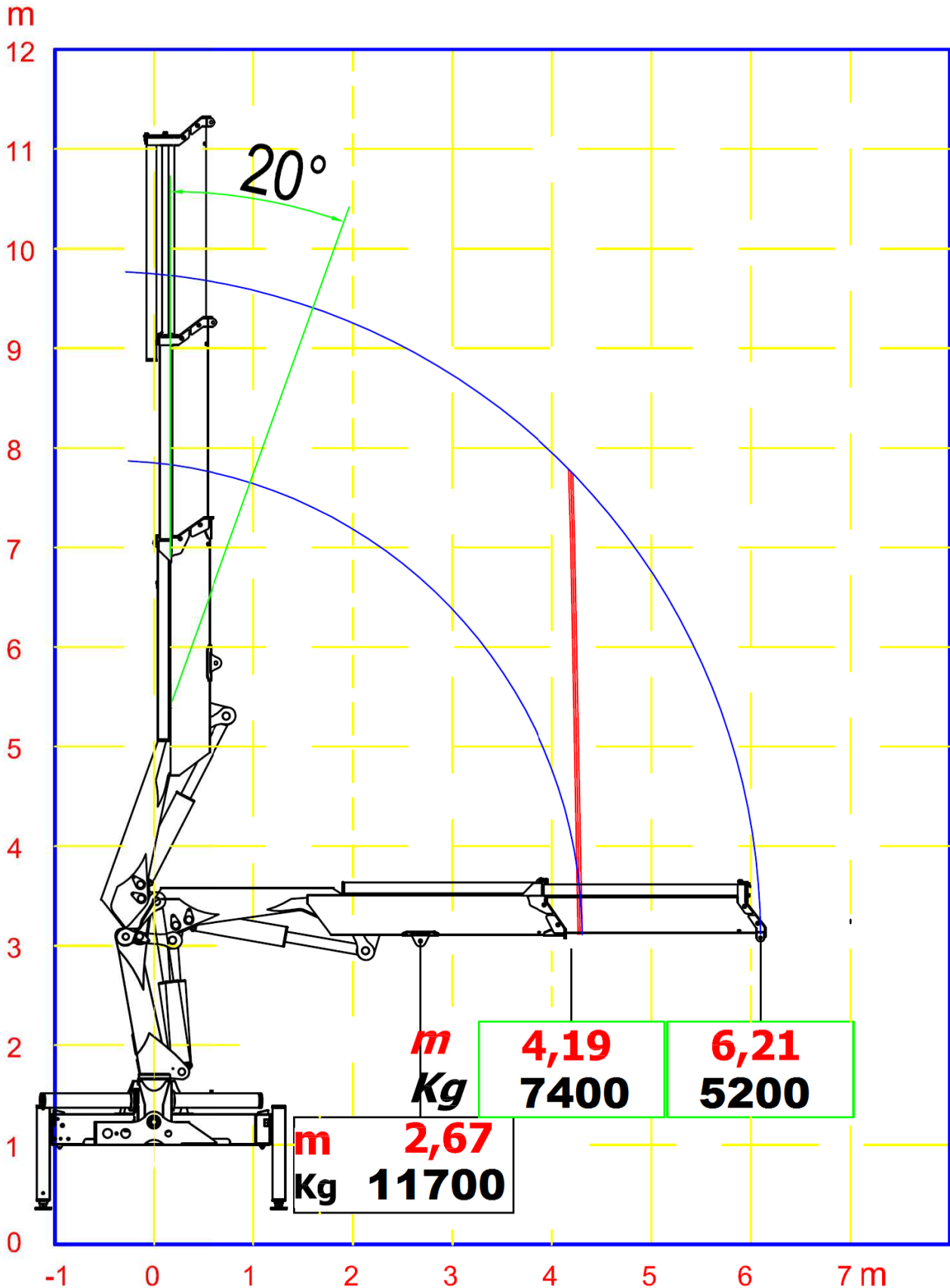

HC 350 A2

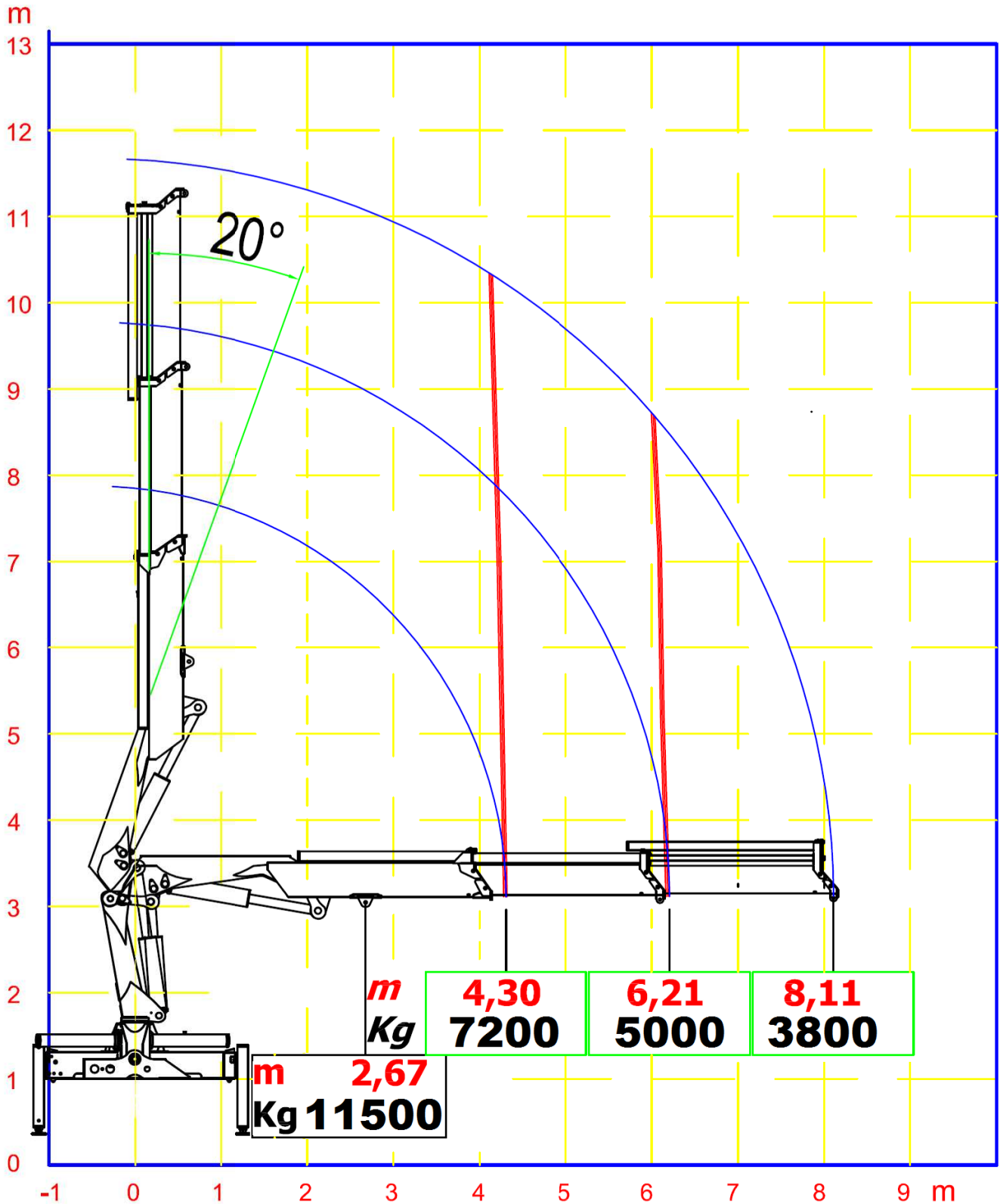

HC 350 A3

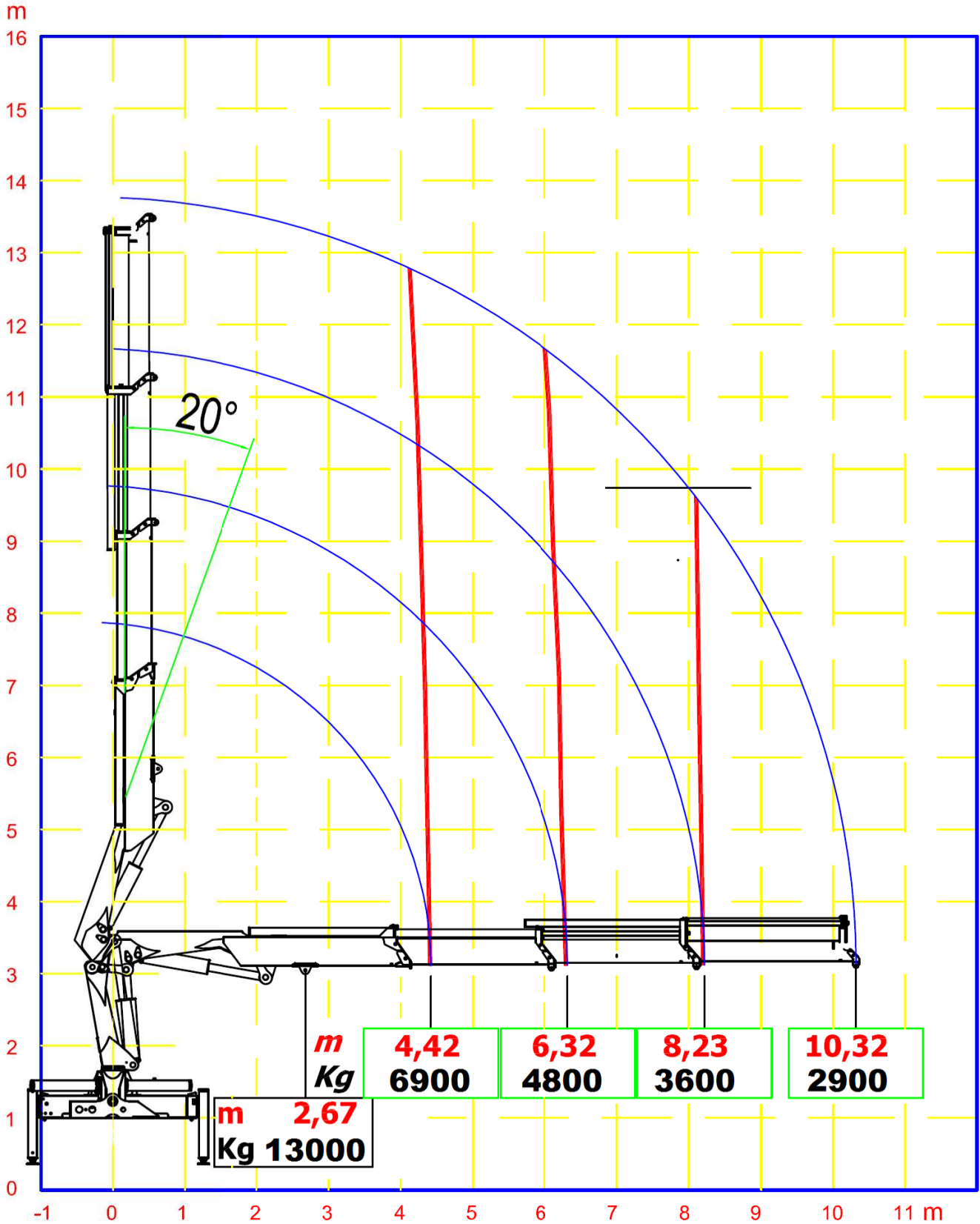

HC 350 A4

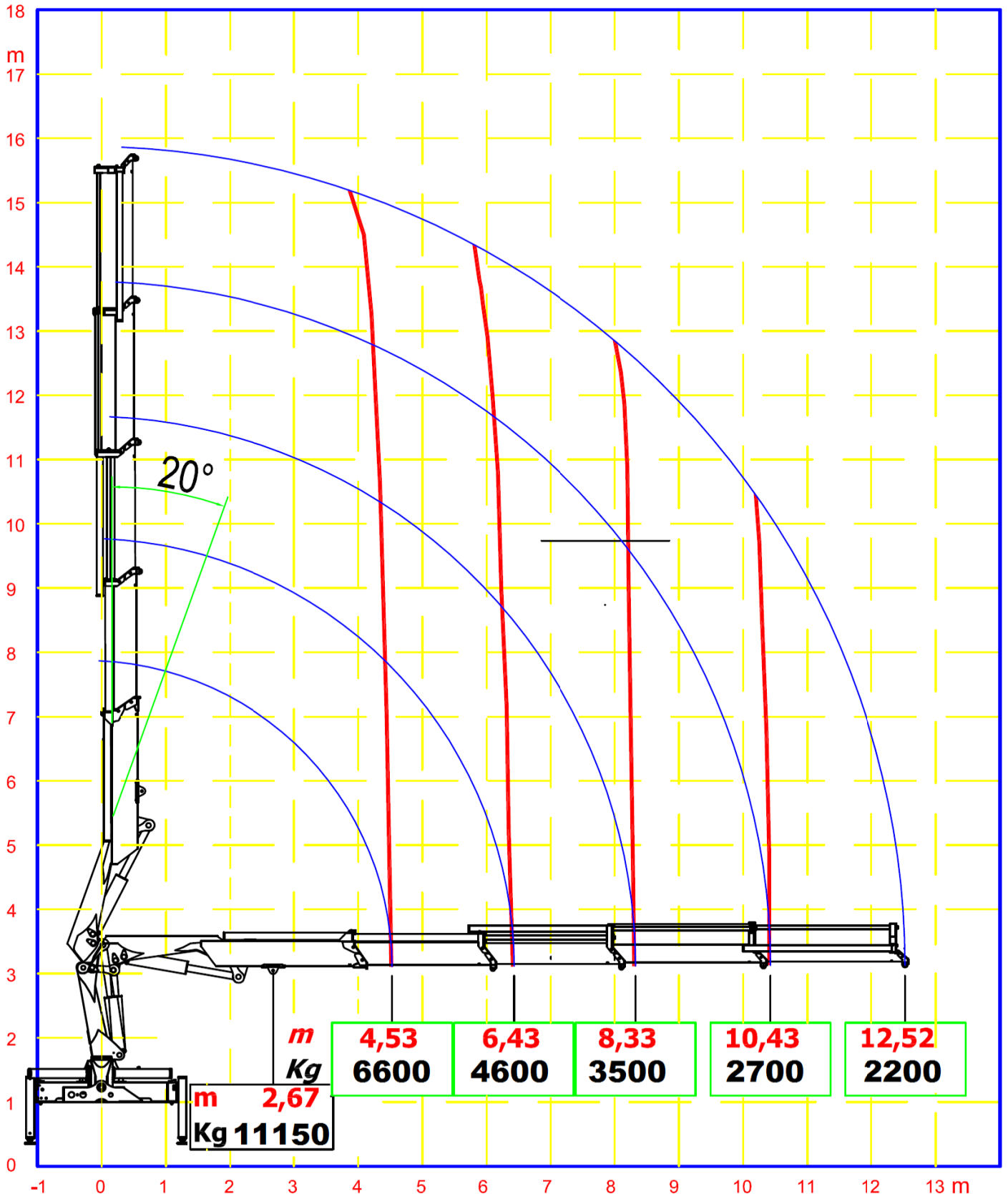

HC 350 A5

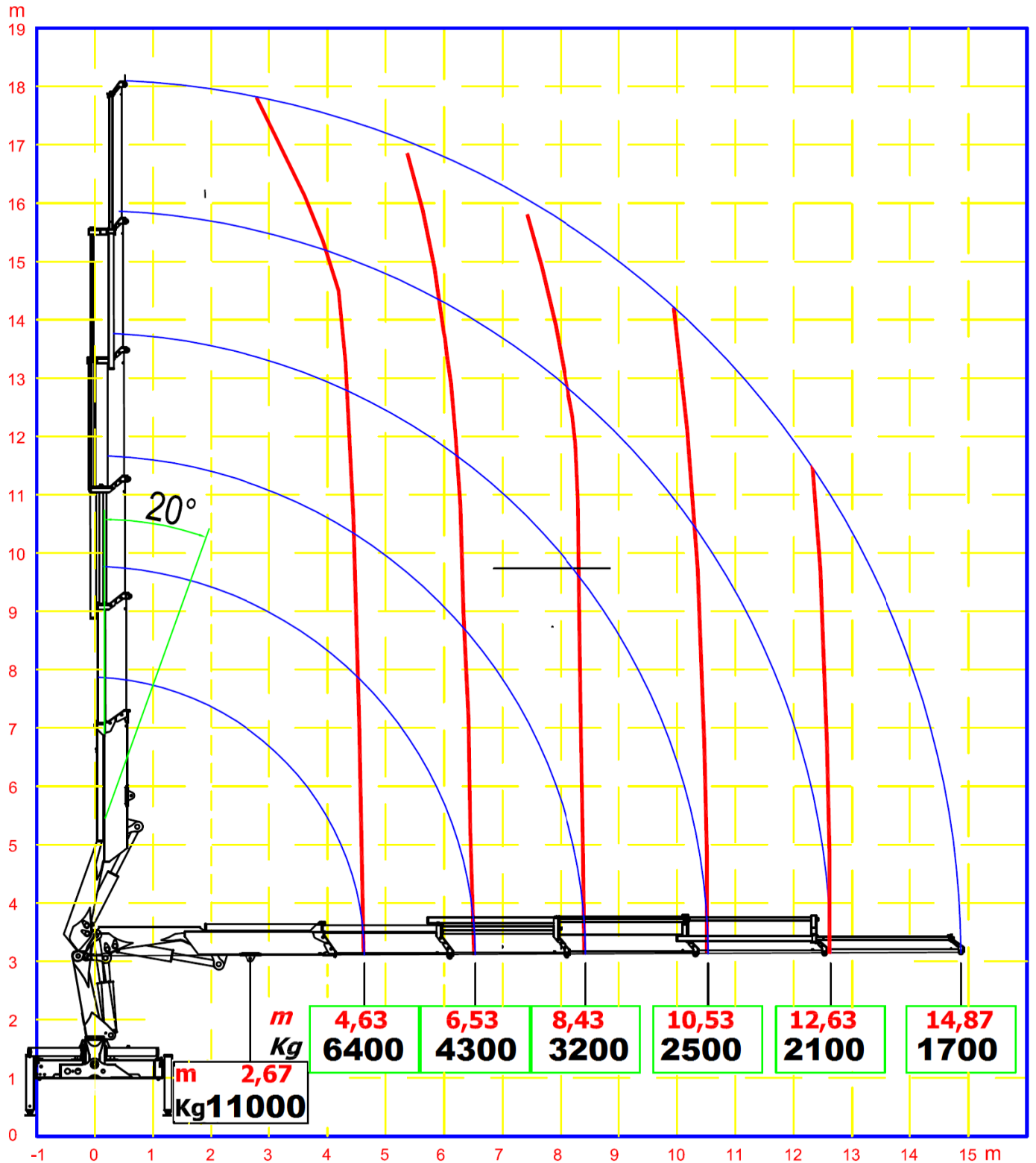

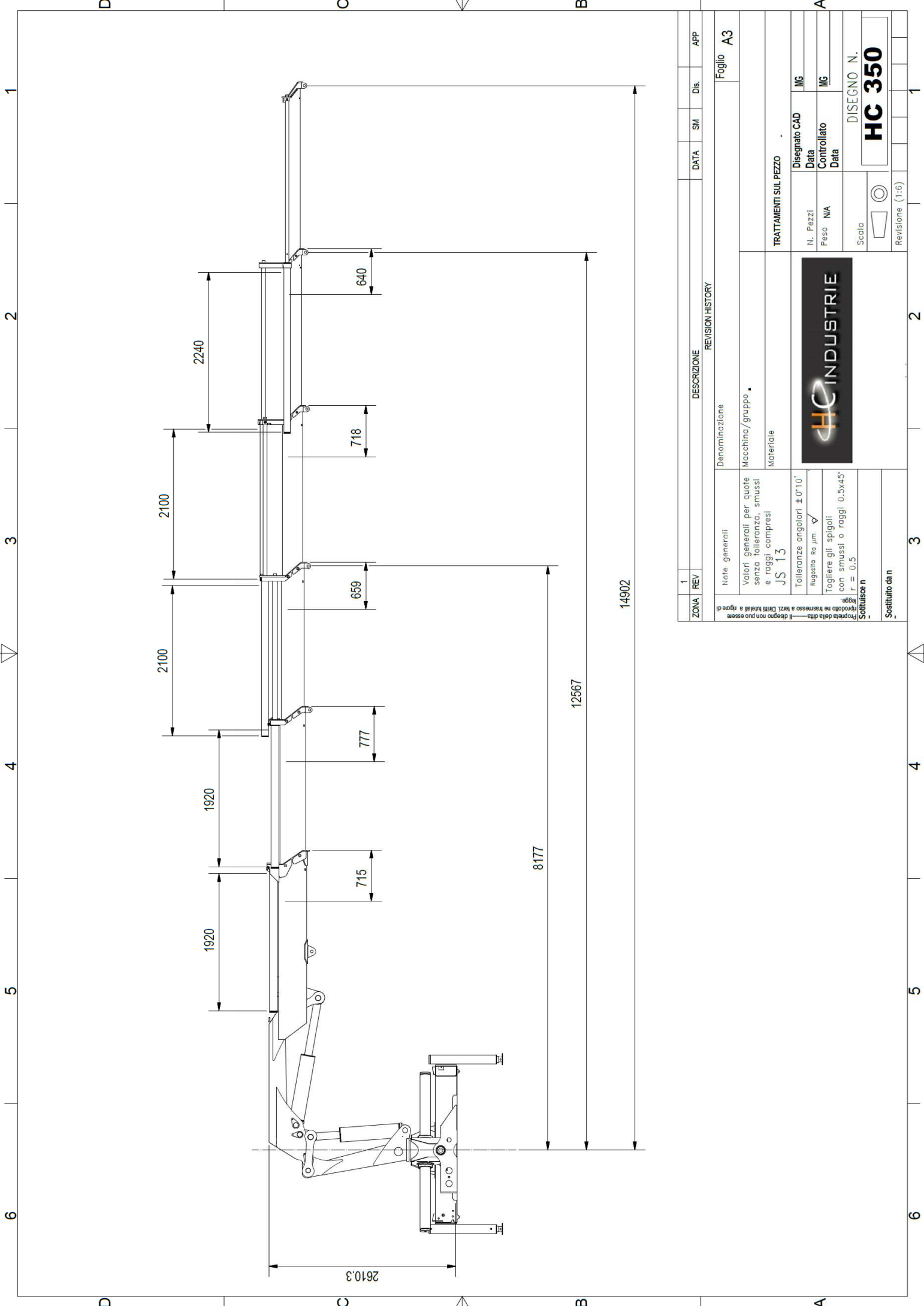

ZONA	REV	DESCRIZIONE	DATA	SM	Dis.	APP
1						
Note generali		Denominazione				
Valori generali per quote senza tolleranza, smussi e raggi compresi JS 13		Macchina/gruppo				
Tolleranze angolari $\pm 0'10''$		Materiale				
Rugosità Ra μm <input checked="" type="checkbox"/>		Disegnato CAD				
Togliere gli spigoli con smussi o raggi 0,5x45°		Data				
R = 0,5		N. Pezzi				
Saldatura n		Peso N/A				
Sostituito da n		Data				
		DISEGNO N.				
		HC 350				
		Revisione (1:6)				
		1				

REVISION HISTORY		Foglio	
TRATTAMENTI SUL PEZZO		A3	
Disegnato CAD		MG	
Data		MG	
N. Pezzi		MG	
Peso N/A		MG	
Data		MG	
DISEGNO N.		MG	
Scala		MG	
Revisione (1:6)		MG	
1		MG	